

980L

Wheel Loader



Engine

Engine Model	Cat® C13 ACERT™	
Maximum Power – ISO 14396	303 kW	412 hp (metric)
Maximum Net Power – ISO 9249	278 kW	378 hp (metric)

Buckets

Bucket Capacities	4.2-12.2 m ³
Weight	
Operating Weight	30 090 kg*

*For 5.4 m³ general purpose bucket with BOCE.

The new 980L Wheel Loader applies proven technologies systematically and strategically to meet your high expectations for reliability, productivity, fuel efficiency, and long service life.



Contents

Reliable	4
Durable	5
Productive	6
Fuel Efficient	7
Easy to Operate	8
Serviceable	9
Cat Connect Technology	10
Versatile	11
Owning Costs	12
Operating Costs	13
Specifications	14
Standard Equipment	22
Optional Equipment	23



Reliability

- Cat C13 ACERT engine offers a combination of proven electronic, fuel and air systems and meets U.S. EPA Tier 2/EU Stage II equivalent or China Nonroad Stage III emission standards and Tier 3/Stage IIIA equivalent emission standards depending on emission standards of specific country.
- Utilizing rigorous component design and machine validation processes results in unmatched reliability, durability and high uptime.

Durability

- Heavy-duty powershift transmission and axles handle extreme applications.
- Improved hydraulic hose routing reduces potential hose wear.
- Full flow hydraulic filtration system with additional loop filtration improves hydraulic system robustness and component life.

Productivity

- Increased engine power improves machine performance and response.
- Lock-up clutch torque converter, combined with lock-to-lock shifting, delivers smooth shifts, fast acceleration and speed on grade.
- High capacity torque converter results in greater digging efficiency.
- Easy-to-load Performance Series Buckets feature a wider mouth and curved side plates that improve material retention (fill factor) and decrease cycle times.

Fuel Efficiency

- Up to 25% lower fuel consumption than H Series.*
- Power dense ACERT engine burns less fuel by providing power and torque when needed.

*Actual results may vary based on factors such as, but not limited to, machine configuration, operator technique, machine application, climate, etc.

Ease of Operation

- New best-in-class operator environment provides unmatched comfort, visibility, and efficiency.
- Intuitive, ergonomic controls keep operators focused on their work.

Safety

- Excellent cab access with wide door and stair-like steps.
- Floor to ceiling windshield, large mirrors with integrated spot mirrors and rear vision camera provide industry leading all-around visibility.

Serviceability

- One-piece tilting hood with side and rear doors; hydraulic and electrical service centers make access fast and easy.
- Safe ground level access to fuel fill, oil fill, filters and daily maintenance points means less servicing time required.

Reliable

Proven components and technology you can count on.



Caterpillar Designed Components

- Utilizing rigorous design and machine validation processes have delivered unmatched reliability, durability and high uptime for generations.
- Components used to build Cat wheel loaders are designed and manufactured to Caterpillar quality standards to ensure maximum performance even in extreme operating conditions.
- Heavy duty components reduce the risk of premature wear resulting in increased uptime and reduce operating costs over the lifetime of the machine.

Equipment Monitoring

- Monitoring product health is key to maintaining reliability of any equipment.
- Cat Connect technologies (Product Link™, VisionLink®) take the guesswork out of equipment management.
- Many programs offered by your Cat dealer make tracking your machine health quick and easy.

Renowned Cat Dealer Support

- Cat dealers provide the best support when it comes to servicing your machine, increasing your uptime on the job site.
- Preventive maintenance programs like Scheduled Oil Sampling (S-O-SSM) analysis or comprehensive Customer Support Agreements help reduce lifetime maintenance costs.
- Best-in-class parts availability maximizes uptime.



Durable
Better designed to meet your needs.

Power Train

- Cat C13 engine with ACERT technology maintains engine performance, efficiency and durability.
- Rugged, planetary powershift transmission and axles handle extreme applications effectively resulting in reliable performance and durable life.
- Front axle is rigidly mounted to the frame in order to withstand internal torque loads and still maintain support for the wheel loader.
- Rear axle can oscillate to ± 13 degrees helping to ensure all four wheels stay on the ground providing stability even in the roughest terrain, for excellent stability and traction.

Hydraulic System

- Improved hydraulic hose routing reduces potential hose wear.
- Full flow hydraulic filtration system with additional loop filtration improves hydraulic system robustness and component life.

Linkage, Buckets and Frames

- Proven Z-bar linkage with Performance Series Buckets offers excellent penetration into the pile, high breakout forces, good roll back angles and faster dig times resulting in improved tire life, superior fuel efficiency and exceptional production capabilities.
- Robotically welded two-piece structural frame design provides strong and rigid structures that absorb all the forces associated to penetration, loading and twisting.
- The L Series articulating hitch system, joins the front and rear frames, providing increased bearing force capacity.

Productive

Work smart and move more.



Engine

- Increased engine power in the 980L by approximately 5% (compared to H series) improves machine performance and response.

Transmission

- Heavy-duty powershift transmission includes a lock up clutch torque converter that matches engine power and hydraulics to maximize machine performance and fuel efficiency.

Performance Series Buckets

- Easy-to-load Performance Series Buckets feature wider mouth, longer floor and curved side plates that improve material retention (fill factor) and decrease cycle times.

Dealer Support

- Your Cat dealer can help with operator training to help boost your productivity and profits.

Fine-tuned Technologies for the Right Applications

- Lock-up clutch torque converter, combined with lock-to-lock shifting, delivers smooth shifts, fast acceleration and speed on grade.
- High capacity torque converter results in greater digging efficiency.
- Z-bar linkage provides high breakout force at ground level in bucket applications.
- Optional aggregate packages are available for specific loose aggregate rehandling applications, such as truck loading, hopper charging, stockpiling, and load and carry.*
- Optional high lift linkage offers increased hinge pin height to load more easily.
- Optional limited slip differentials improve performance in the pile and poor underfoot conditions with no operator intervention required.

*Please consult your Cat dealer to ensure proper machine configuration selection in conformance to Caterpillar payload policy.



Fuel Efficient

Engineered to lower your operating costs.

Engine and Emissions

- Cat C13 ACERT engine is designed for maximum fuel efficiency and increased power density. Based on local requirements, meets Tier 2/Stage II equivalent or China Nonroad Stage III emission standards and Tier 3/Stage IIIA equivalent emission standards, depending on emission standards of specific country.
- Engine features innovative Cat electronics, fuel injection process, and air-management systems, reducing fuel consumption.

Efficient Systems and Components

- Innovative systems intelligently lower average working engine speeds and reduce overall system heat loads resulting in significantly improved performance and fuel efficiency.

Advanced Systems with Innovative Integration

- Deep system integration of new engine power train, hydraulic system and cooling system result in lower fuel consumption on average compared to H Series.

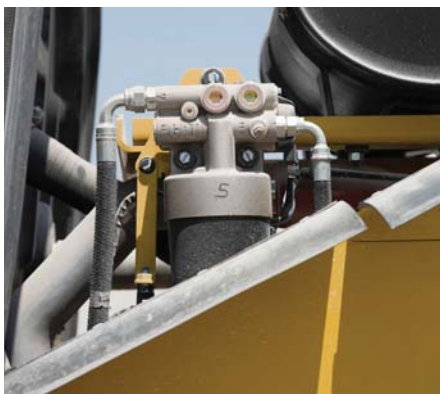

- Up to 25% lower fuel consumption than H Series.*
- Power dense ACERT engine burns less fuel by providing power and torque when needed.
- Performance Series Buckets feature a longer floor that easily digs through the pile resulting in lower fuel consumption.
- Productive Economy Mode provides maximum fuel savings with minimal productivity impact.
- Load sensing hydraulics result in proportional flow for implement and steering on demand.
- On-Demand Fan improves fuel efficiency, lower noise levels and reduced radiator plugging.
- Engine Idle Management System (EIMS) maximizes fuel efficiency by reducing engine rpm.
- Engine Idle Shutdown saves fuel and reduces hour accumulation on your machine.

*Actual results may vary based on factors such as, but not limited to, machine configuration, operator technique, machine application, climate, etc.

Easy to Operate

Safe. Comfortable. Efficient.



Operator Environment

- New best-in-class operator environment features four post Roll Over Protection System (ROPS) cab providing unmatched comfort, visibility, and efficiency.
- Seat-mounted implement controls, low effort steering wheel and streamlined control panel provide operators with precise control of work tool and machine with maximum comfort and efficiency.
- Viscous cab mounts connect cab to frame of machine, decreasing noise and vibration resulting in a sustainable work environment and well-rested efficient, productive operator.
- Load-sensing implement hydraulic system, allowing comfortable combined movement to improve operation efficiency.
- Optional new ride control system with dual accumulators provides excellent ride quality and lowers cab vibrations.



Safety

- Excellent cab access with wide door and stair-like steps.
- Floor to ceiling windshield, large mirrors with integrated spot mirrors and rear vision camera provide industry leading all-around visibility.
- Robust, repositioned grab bars provide safe access to machine platforms.
- Integrated rear vision camera enhances visibility behind machine helping operators work safely and productively.



Serviceable

Easy to maintain. Easy to service.



Engine Access

- One-piece tilting hood with side and rear doors makes access fast and easy.
- Best-in-class service access to engine, oil levels and coolant sight gauge means less servicing time required.

Service Centers

- Electrical and hydraulic service centers provide grouped ground level access enhancing safety and convenience while reducing service time.
- Convenient, ground level access to fuel fill and daily maintenance points means safer and faster servicing time.

Parking Brake

- External caliper disc parking brakes are easily accessible for inspection and service.

Cooling System

- Cooling system is readily accessible for clean out and maintenance.
- Hydraulic and A/C cooler cores swing out providing easy access to both sides for cleaning.
- Access panel on left side of cooling package swings down to provide access to back side of engine coolant and Air-to-Air After Cooler (ATAAC).
- Optional variable pitch fan can automatically purge cooler cores by periodically reversing airflow when needed.

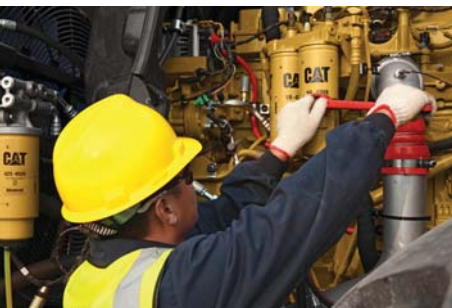

Cat Connect Technology

Monitor, manage, and enhance job site operations.



LINK Technologies

VisionLink enables owners to access data wirelessly to monitor machine health, utilization and location.

PAYLOAD Technologies

Accurately weigh materials being loaded and hauled to improve productivity, reduce overloading, and track material movement.

Cat Production Measurement (optional)

Provides simple, accurate, on-the-go weighing to assist operators in delivering exact loads and working more efficiently.

- Intuitive user interface, within standard touch screen display, provides essential payload information in an easy-to-read, user-friendly format.
- Site managers can wirelessly access data via the VisionLink web portal to measure production and monitor efficiency.

DETECT Technologies

Enhance operator awareness of the environment around working equipment and provide alerts to help keep people and assets safe.

Rear Vision Camera

- Integrated rear vision camera enhances visibility behind machine.



Versatile

Do more jobs with one machine.

Heavy Duty Quarry Rock Buckets

- Bank or face loading material where high impact/high abrasion is encountered.
- Thicker base edge, liner package and addition wear plates.

Slag Buckets

- Increased material thickness in critical structural components to provide maximum durability for hot or cold slag handling.

Waste Handling Buckets

- Move large volumes of low-density waste in transfer stations, landfills and recycling yards for maximum production when loading conveyors, trucks or hoppers.

Woodchip Buckets

- Optimized for moving large volumes of wood chips in forestry and millyard settings.
- Flat floor and straight edge designed to scoop the bucket full and help heap the load high.



Performance Series Buckets

Load Easy, Fuel Efficient, Carry More

- Buckets utilize a system based approach to balance bucket shape with machine's linkage, weight, lift and tilt capacities.
- Reduced dig times and better material retention results in significant productivity and fuel efficiency improvements.

Lower Operating Costs

- Buckets feature longer floor that easily digs through pile and provides excellent visibility for operators to see when bucket is full.
- Less time digging in the pile results in lower fuel consumption and improved tire life.
- Unique spill guard protects cab and linkage components from material overflow.

Higher Productivity

- Buckets achieve higher fill factors – ranging from 100% to 115% depending on the machine application and material type.
- Buckets feature curved side profile to maximize material retention.

Owning Costs

Proven best investment.



Cat Product Link

- Cat Product Link allows remote monitoring of equipment to improve overall fleet management effectiveness.
- Product Link is deeply integrated into machine systems; information such as events, diagnostic codes, hours, fuel, idle time and other detailed information are transmitted to a secure web based application, VisionLink.
- VisionLink includes powerful tools to convey information to users and dealers, including mapping, working and idle time, fuel level and more.

S-O-S Services

- Helps manage component life and decrease machine downtime, increasing productivity and efficiency.
- Regular fluid sampling can help track what is going on inside your machine. Wear related problems are predictable and proactively repairable.
- Maintenance can be done to accommodate your schedule, resulting in increased uptime and flexibility in maintenance repairs before failure.

Parts Availability

- Caterpillar provides an unsurpassed level of personalized service to help you work more cost effectively and efficiently.
- By utilizing a worldwide parts network Cat dealers help minimize machine downtime and save money by fast delivery of replacement parts.

Resale Value

- Caterpillar is not only known for machines that are better built, but provides product and dealer support to maintain the reliability and durability of your machine.

Operating Costs

Save time and money by working smart.



Most Fuel Efficient Machines in Industry

- Data from customer machines show Cat wheel loaders are the most fuel efficient machines in the industry.

Engine, Hydraulics and Transmission

- Deep system integration results in more productivity, lower fuel consumption, without interrupting machine performance – making it seamless to you and your operators.

Lock-up-Clutch Torque Converter and Shift Strategy

- Reduced torque interruption increases driveline efficiency, conserving fuel; auto transmission mode keeps engine rpm low, reducing fuel consumption while delivering optimal machine performance.

Performance Series Buckets

- Performance Series buckets deliver faster fill times and better material retention, ultimately reducing cycle times while improving productivity and fuel efficiency.

External Caliper Disc Parking Brake

- External caliper disc parking brake does not have the inefficiencies of enclosed wet parking brakes due to brake discs running in oil nor is there any oil to change reducing fuel and maintenance costs.

980L Wheel Loader Specifications

Engine

Engine Model	Cat C13 ACERT	
Maximum Power (1,800 rpm)		
ISO 14396	303 kW	412 hp (metric)
Maximum Net Power (1,800 rpm)		
ISO 9249	278 kW	378 hp (metric)
Peak Gross Torque (1,300 rpm)		
ISO 14396	2172 N·m	
Maximum Net Torque (1,000 rpm)		
ISO 9249	2040 N·m	
Bore	130 mm	
Stroke	157 mm	
Displacement	12.5 L	

- Cat engine with ACERT Technology – based on local requirements, meets Tier 2/Stage II equivalent or China Nonroad Stage III emission standards and Tier 3/Stage IIIA equivalent emission standards.
- The power ratings apply at the stated speed when tested under the reference conditions for the specified standards.
- The net power advertised is the power available at the flywheel when the engine is equipped with fan, alternator, air cleaner and aftertreatment.
- The gross power advertised is with the fan at maximum speed.

Buckets

Bucket Capacities	4.2-12.2 m ³
-------------------	-------------------------

Weight

Operating Weight	30 090 kg
------------------	-----------

- Weight based on a machine configuration with Michelin 29.5R25 XLDD1 L4 radial tires, full fluids, operator, standard counterweight, cold start, roading fenders, Product Link, open differential axles (front/rear), secondary steering, sound suppression, and a 5.4 m³ general purpose bucket with BOCE.

Operating Specifications

Static Tipping Load – Full 40° Turn		
With Tire Deflection	19 565 kg	
No Tire Deflection	20 796 kg	
Breakout Force	224 kN	

- Full compliance to ISO (2007) 143971 Sections 1 thru 6, which requires 2% verification between calculations and testing.

Transmission

Forward 1	6.9 km/h
Forward 2	13.3 km/h
Forward 3	23.5 km/h
Forward 4	39.5 km/h
Reverse 1	7.8 km/h
Reverse 2	15.2 km/h
Reverse 3	26.9 km/h
Reverse 4	39.5 km/h

- Maximum travel speed in standard vehicle with empty bucket and standard L4 tires with 933 mm roll radius.

Hydraulic System

Implement Pump Type	Variable Displacement Piston
Implement System	
Maximum Pump Output (2,250 rpm)	449 L/min
Maximum Operating Pressure	34 300 kPa
Optional 3rd Function Maximum Flow	240 L/min
Optional 3rd Function Maximum Pressure	21 780 kPa
Hydraulic Cycle Time with Rated Payload:	
Raise from Carry Position	5.3 Seconds
Dump, at Maximum Raise	1.7 Seconds
Lower, Empty, Float Down	3.1 Seconds
Total	10.1 Seconds

Brakes

Brakes	Brakes meet ISO 3450 standards
--------	--------------------------------

Axles

Front	Fixed
Rear	Oscillating ±13 degrees
Maximum Single-Wheel Rise and Fall	549 mm

Cab

ROPS/FOPS	ROPS/FOPS meet ISO 3471 and ISO 3449 Level II standards
-----------	---

980L Wheel Loader Specifications

Sound

The sound values indicated below are for specific operating conditions only. Machine and operator sound levels will vary at different engine and/or cooling fan speeds. Hearing protection may be needed when the machine is operated with a cabin that is not properly maintained, or when the doors and/or windows are open for extended periods or in a noisy environment.

With Cooling Fan Speed at Maximum Value:

Operator Sound Pressure Level (ISO 6396:2008)	75 dB(A)
Exterior Sound Power Level (ISO 6395:2008)	112 dB(A)
Exterior Sound Pressure Level (SAE J88:2013)	78 dB(A)*

With Cooling Fan Speed at 70% of Maximum Value:**

Operator Sound Pressure Level (ISO 6396:2008)	72 dB(A)
Exterior Sound Power Level (ISO 6395:2008)	109 L _{WA} ***

*Distance of 15 m, moving forward in second gear ratio.

**For machines in countries that adopt the “EU Directives.”

***European Union Directives “2000/14/EC” as amended by “2005/88/EC.”

Service Refill Capacities

Fuel Tank	426 L
Cooling System (Tier 2 and Tier 3)	45 L
Crankcase	37 L
Transmission	77 L
Differentials and Final Drives – Front	84 L
Differentials and Final Drives – Rear	84 L
Hydraulic Tank	153 L

980L Wheel Loader Specifications

Dimensions

All dimensions are approximate.

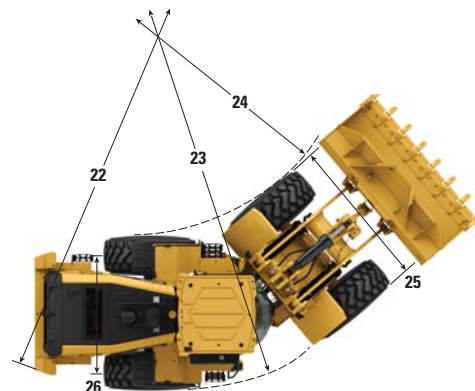
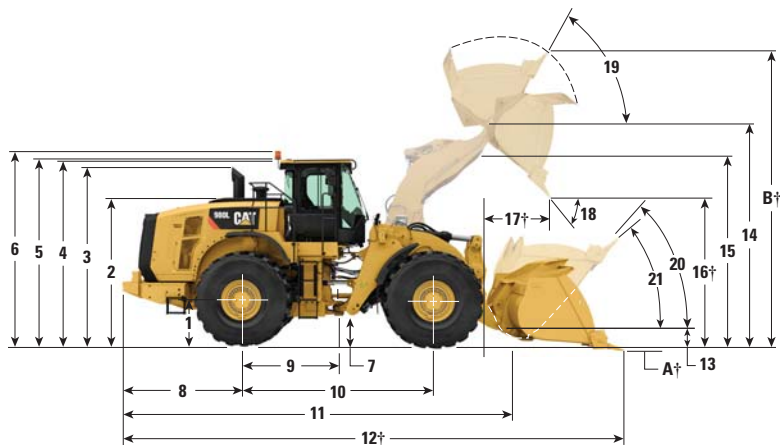

	Standard Lift	High Lift
1 Height to Axle Centerline	892 mm	892 mm
2 Height to Top of Hood	3110 mm	3110 mm
3 Height to Top of Exhaust Pipe	3746 mm	3746 mm
4 Height to Top of ROPS	3813 mm	3813 mm
5 Height to Top of Product Link Antenna	3891 mm	3891 mm
6 Height to Top of Warning Beacon	4112 mm	4112 mm
7 Ground Clearance	453 mm	453 mm
8 Center Line of Rear Axle to Edge of Counterweight	2608 mm	2608 mm
9 Center Line of Rear Axle to Hitch	1900 mm	1900 mm
10 Wheelbase	3800 mm	3800 mm
11 Overall Length (without bucket)	8214 mm	8302 mm
12 Shipping Length (with bucket level on ground)*†	9627 mm	9715 mm
13 Hinge Pin Height at Carry Height	621 mm	678 mm
14 Hinge Pin Height at Maximum Lift	4539 mm	4760 mm
15 Lift Arm Clearance at Maximum Lift	3795 mm	4010 mm
16 Dump Clearance at Maximum Lift and 45° Discharge*†	3273 mm	3493 mm
17 Reach at Maximum Lift and 45° Discharge*†	1481 mm	1484 mm
18 Dump Angle at Maximum Lift and Dump (on stops)*	52 degrees	55 degrees
19 Rack Back at Maximum Lift*	61 degrees	61 degrees
20 Rack Back at Carry Height*	48 degrees	48 degrees
21 Rack Back at Ground*	40 degrees	39 degrees
22 Clearance Circle (radius) to Counterweight	13 683 mm	13 683 mm
23 Clearance Circle (radius) to Outside of Tires	14 806 mm	14 806 mm
24 Clearance Circle (radius) to Inside of Tires	8252 mm	8252 mm
25 Width Over Tires – Maximum (unloaded)	3265 mm	3265 mm
Width Over Tires – Maximum (loaded)	3296 mm	3296 mm
26 Tread Width	2440 mm	2440 mm

*With 5.4 m³ general purpose pin on bucket with BOCE (see Operating Specifications for other Buckets).

†Dimensions are listed in Operating Specifications charts.

All height and tire related dimensions are with Michelin 29.5R25 XLDD1 L4 radial tires (see Tire Option Chart for other tires).

“Width Over Tires” dimensions are over the bulge and include growth.

980L Wheel Loader Specifications

Tire Option Chart (Compared to Michelin XLDD1 L4)

Tire Brand	Michelin	Michelin	Michelin	Bridgestone	Bridgestone	Bridgestone
Tire Size	29.5R25	29.5R25	29.5R25	29.5R25	29.5R25	29.5R25
Tread Type	L-3	L-5	L-5	L-3	L-4	L-5
Tread Pattern	XHA2	XLDD2	XMINE D2	VMT	VSNT	VSDL
Width over Tires – Maximum (unloaded)*	3273 mm	3269 mm	3281 mm	3257 mm	3243 mm	3252 mm
Width over Tires – Maximum (loaded)*	3293 mm	3297 mm	3295 mm	3284 mm	3265 mm	3274 mm
Change in Vertical Dimensions (average of front and rear)	-33 mm	-6 mm	9 mm	-21 mm	4 mm	23 mm
Change in Horizontal Reach	23 mm	3 mm	3 mm	21 mm	1 mm	-10 mm
Change in Clearance Circle to Outside of Tires	-4 mm	1 mm	-2 mm	-13 mm	-32 mm	-23 mm
Change in Clearance Circle to Inside of Tires	4 mm	-1 mm	2 mm	13 mm	32 mm	23 mm
Change in Operating Weight (without Ballast)	-544 kg	364 kg	688 kg	-356 kg	156 kg	864 kg

*Width over tire bulge and includes tire growth.

Changes Specific to the 980L

Tire Brand	Michelin	Michelin	Michelin	Bridgestone	Bridgestone	Bridgestone
Tire Size	29.5R25	29.5R25	29.5R25	29.5R25	29.5R25	29.5R25
Tread Type	L-3	L-5	L-5	L-3	L-4	L-5
Tread Pattern	XHA2	XLDD2	XMINE D2	VMT	VSNT	VSDL
Change in Static Tipping Load – Straight	-411 kg	275 kg	519 kg	-269 kg	118 kg	652 kg
Change in Static Tipping Load – Articulated	-357 kg	239 kg	452 kg	-234 kg	102 kg	568 kg

980L Wheel Loader Specifications

Bucket Fill Factors and Selection Chart

The bucket size must be chosen based on the density of the material and on the expected fill factor. The new Cat Performance Series Buckets with longer floor, larger bucket opening, increased repository angle, rounded side boards and integrated spill guard, demonstrate fill factors significantly higher than previous generation or non Cat buckets. The actual volume handled by the machine is thus often larger than the rated capacity.

Loose Material		Material Density	Fill Factor (%)*
Earth/Clay		1500-1700 kg/m ³	115
Sand and Gravel		1500-1700 kg/m ³	115
Aggregate:	25-76 mm	1600-1700 kg/m ³	110
	19 mm and smaller	1800 kg/m ³	105
Rock:	76 mm and larger	1600 kg/m ³	100

*As a % of ISO rated capacity.

Note: Fill Factors achieved will also depend on whether the product is washed or not washed.

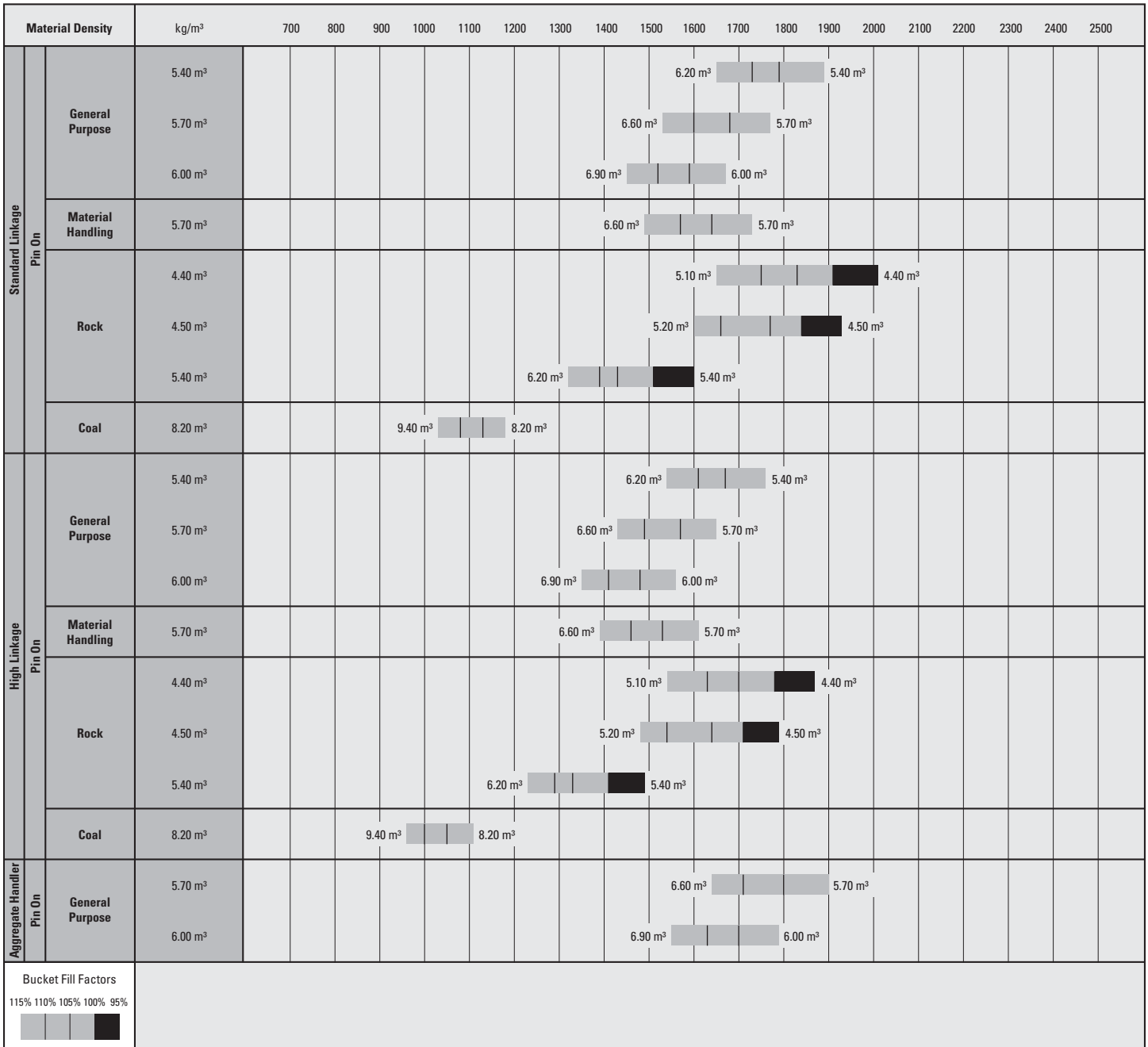

Note: All buckets are showing Bolt-on Edges except the Rock Bucket is showing Tips.

980L Wheel Loader Specifications

Operating Specifications with Buckets

Linkage		Standard Linkage						High Lift Linkage**
Bucket Type		General Purpose – Pin On						
Edge Type		Bolt-On Cutting Edges	Teeth and Segments	Bolt-On Cutting Edges	Teeth and Segments	Bolt-On Cutting Edges	Teeth and Segments	
Capacity – Rated	m ³	5.4	5.4	5.7	5.7	6.0	6.0	
Capacity – 110%	m ³	5.9	5.9	6.3	6.3	6.6	6.6	
Width	mm	3447	3535	3447	3535	3447	3535	
16 † Dump Clearance at Maximum Lift and 45° Discharge	mm	3273	3107	3204	3037	3187	3019	220
17 † Reach at Maximum Lift and 45° Discharge	mm	1481	1618	1529	1663	1550	1685	2
Reach at Level Lift Arm and Bucket Level	mm	2965	3177	3049	3261	3077	3289	160
A † Digging Depth	mm	103	103	103	103	103	103	-1
12 † Overall Length	mm	9493	9734	9577	9818	9605	9846	201
B † Overall Height with Bucket at Maximum Lift	mm	6421	6421	6243	6243	6269	6269	221
Loader Clearance Circle Radius with Bucket at Carry Position	mm	7612	7726	7635	7749	7643	7757	1009
Static Tipping Load, Straight (ISO)*	kg	22 639	22 453	22 391	22 204	22 249	22 062	-1938
Static Tipping Load, Straight (Rigid Tire)*	kg	24 023	23 835	23 775	23 586	23 635	23 446	-2144
Static Tipping Load, Articulated (ISO)*	kg	19 565	19 379	19 334	19 147	19 197	19 009	-1320
Static Tipping Load, Articulated (Rigid Tire)*	kg	20 796	20 608	20 567	20 378	20 432	20 243	-1500
Breakout Force	kN	226	224	213	211	209	207	3
Operating Weight*	kg	30 090	30 228	30 173	30 311	30 269	30 407	115

*Static tipping loads and operating weights shown are based on a machine configuration with Michelin 29.5R25 XLDD1 L4 radial tires, full fluids, operator, standard counterweight, cold start, roading fenders, Product Link, open/open axles (front/rear), power train guard, secondary steering and sound suppression.

(ISO) Full compliance to ISO 14397-1 (2007) Sections 1 thru 6, which requires 2% verification between calculations and testing.

(Rigid Tire) Compliance to ISO 14397-1 (2007) Sections 1 thru 5.

**Maximum values.

†Illustration shown with Dimension charts.

980L Wheel Loader Specifications

Operating Specifications with Buckets

Linkage		Standard Linkage						High Lift Linkage Change**
Bucket Type		Material Handling – Pin On		Rock – Pin On		Coal – Pin On		
Edge Type		Bolt-On Cutting Edges	Teeth and Segments	Teeth and Segments	Teeth and Segments + Side Protector	Teeth + Side Protector	Bolt-On Cutting Edges	
Capacity – Rated	m ³	5.7	5.7	4.4	4.5	5.4	8.2	
Capacity – 110%	m ³	6.3	6.3	4.8	5.0	5.9	9.0	
Width	mm	3447	3535	3504	3504	3504	3638	
16 † Dump Clearance at Maximum Lift and 45° Discharge	mm	3105	2928	3101	3051	2890	2917	220
17 † Reach at Maximum Lift and 45° Discharge	mm	1444	1566	1769	1713	1904	1625	2
Reach at Level Lift Arm and Bucket Level	mm	3074	3286	3285	3284	3533	3336	160
A † Digging Depth	mm	103	103	106	106	71	108	-1
12 † Overall Length	mm	9602	9843	9828	9827	10 076	9867	201
B † Overall Height with Bucket at Maximum Lift	mm	6242	6242	6184	6204	6378	6536	221
Loader Clearance Circle Radius with Bucket at Carry Position	mm	7642	7756	7735	7734	7807	7805	1009
Static Tipping Load, Straight (ISO)*	kg	21 892	21 708	23 033	22 740	22 412	21 615	-1938
Static Tipping Load, Straight (Rigid Tire)*	kg	23 234	23 048	24 431	24 137	23 824	23 054	-2144
Static Tipping Load, Articulated (ISO)*	kg	18 888	18 704	19 875	19 589	19 299	18 575	-1320
Static Tipping Load, Articulated (Rigid Tire)*	kg	20 084	19 897	21 117	20 830	20 557	19 864	-1500
Breakout Force	kN	210	207	212	210	193	177	3
Operating Weight*	kg	30 298	30 436	30 687	30 978	31 024	30 677	115

*Static tipping loads and operating weights shown are based on a machine configuration with Michelin 29.5R25 XLDD1 L4 radial tires, full fluids, operator, standard counterweight, cold start, roading fenders, Product Link, open/open axles (front/rear), power train guard, secondary steering and sound suppression.

(ISO) Full compliance to ISO 14397-1 (2007) Sections 1 thru 6, which requires 2% verification between calculations and testing.

(Rigid Tire) Compliance to ISO 14397-1 (2007) Sections 1 thru 5.

**Maximum values.

†Illustration shown with Dimension charts.

980L Wheel Loader Specifications

Operating Specifications with Buckets – Aggregate Handler

Package		Aggregate Handler	
Bucket Type		General Purpose – Pin On	
Edge Type		Bolt-On Cutting Edges	Bolt-On Cutting Edges
Capacity – Rated	m ³	5.7	6.0
Capacity – 110%	m ³	6.3	6.6
Width	mm	3447	3447
16 † Dump Clearance at Maximum Lift and 45° Discharge	mm	3204	3187
17 † Reach at Maximum Lift and 45° Discharge	mm	1529	1550
Reach at Level Lift Arm and Bucket Level	mm	3049	3077
A † Digging Depth	mm	103	103
12 † Overall Length	mm	9638	9666
B † Overall Height with Bucket at Maximum Lift	mm	6243	6269
Loader Clearance Circle Radius with Bucket at Carry Position	mm	7635	7643
Static Tipping Load, Straight (ISO)*	kg	23 972	23 827
Static Tipping Load, Straight (Rigid Tire)*	kg	25 481	25 339
Static Tipping Load, Articulated (ISO)*	kg	20 630	20 491
Static Tipping Load, Articulated (Rigid Tire)*	kg	21 997	21 860
Breakout Force	kN	213	209
Operating Weight*	kg	30 822	30 918

*Static tipping loads and operating weights shown are based on a machine configuration with Michelin 29.5R25 XLDD1 L4 radial tires, full fluids, operator, standard counterweight, cold start, roading fenders, Product Link, open/open axles (front/rear), power train guard, secondary steering and sound suppression.

(ISO) Full compliance to ISO 14397-1 (2007) Sections 1 thru 6, which requires 2% verification between calculations and testing.

(Rigid Tire) Compliance to ISO 14397-1 (2007) Sections 1 thru 5.

**Maximum values.

†Illustration shown with Dimension charts.

Standard Equipment

Standard equipment may vary. Consult your Cat dealer for details.

OPERATOR ENVIRONMENT

- Cab, pressurized and sound suppressed (ROPS/FOPS)
- Viscous mounts
- Rear vision camera within multi-function 18 cm color LCD touch-screen display (*capability for displaying machine status, setting and health parameters*)
- EH controls, SAL (single axis lever) lift and tilt function
- Steering, steering wheel
- Radio ready (entertainment) includes antenna, speakers and converter (12V, 10-amp)
- Air conditioner, heater, and defroster
- EH parking brake
- Beverage holders (2) with storage compartment for cell phone/MP3 player
- Bucket/work tool function lockout
- Coat hook
- Cab air filter
- Ergonomic cab access ladders and handrails
- Horn, electric
- Light, two dome (cab)
- Mirrors, rearview external with integrated spot mirrors
- Post mounted membrane 16 switch keypad
- Two receptacles, 12V
- Seat, Cat Comfort (cloth) air suspension
- Seat belt, 51 mm retractable
- Sun visor, front
- Wet-arm wipers/washers front and rear, intermittent front wiper
- Window, sliding (left and right sides)

COMPUTERIZED MONITORING SYSTEM

- With following gauges:
 - Speedometer/tachometer
 - Digital gear range indicator
 - Temperature: engine coolant, hydraulic oil, transmission oil
 - Fuel level

- With following warning indicators:
 - Temperature: axle oil, engine intake manifold
 - Pressure: engine oil, fuel pressure hi/low, primary steering oil, service brake oil
 - Battery voltage hi/low
 - Engine air filter restriction
 - Hydraulic oil filter restriction
 - Hydraulic oil low
 - Parking brake
 - Transmission filter bypass

ELECTRICAL AND LIGHTING

- Batteries (2), maintenance free 1,400 CCA
- Ignition key; start/stop switch
- Starter, electric, heavy duty
- Starting and charging system (24V)
- Lighting system:
 - Four halogen work lights (cab mounted)
 - Two halogen rear vision lights (hood mounted)
 - Two loader tower mounted working lights
 - Rear LED stop tail lights
- Alarm, back-up
- Alternator, 145-amp brushed
- Main disconnect switch
- Receptacle start (cables not included)

CAT CONNECT TECHNOLOGIES

- Link technologies: Product Link
- Detect technologies: rear vision camera

POWER TRAIN

- Engine, Cat C13 ACERT – meets Tier 2/ Stage II equivalent or China Nonroad Stage III and Tier 3/Stage IIIA equivalent emission standards
- Fuel priming pump (electric)
- Fuel/water separator
- Precleaner, engine air intake
- Productive Economy Mode
- Transmission, automatic planetary power shift (4F/4R)
- Torque converter, locking clutch with free wheel stator

- Switch, transmission neutralizer lockout
- Axles, open differential front and rear axles
- Brakes, full hydraulic enclosed wet-disc with Integrated Braking System (IBS)
- Brake wear indicators
- Parking brake, disc and caliper
- Fan, radiator, electronically controlled, hydraulically driven, temperature sensing, on demand

LINKAGE

- Linkage, Z-bar, cast crosstube/tilt lever
- Kickout, lift and tilt, automatic (adjustable in cab)

HYDRAULICS

- Hydraulic system, load sensing
- Steering, load sensing
- Remote diagnostic pressure taps
- Hoses, Cat XT™
- Couplings, Cat O-ring face seal
- Hydraulic oil cooler (swing out)
- Oil sampling valves

FLUIDS

- Premixed extended life coolant with freeze protection to –34° C

OTHER STANDARD EQUIPMENT

- Hood, non-metallic power tilting
- Service centers (electrical and hydraulic)
- Auto idle shutdown
- Fenders, front
- Ecology drains for engine, transmission, and hydraulics
- Grill, airborne debris
- Filters: fuel, engine air, engine oil, hydraulic oil, transmission
- Grease zerks
- Hitch, drawbar with pin
- Precleaner rain cap
- Sight gauges: engine coolant, hydraulic oil, and transmission oil level
- Vandalism protection caplocks

Optional Equipment

Optional equipment may vary. Consult your Cat dealer for details.

OPERATOR ENVIRONMENT

- Cover, HVAC metallic
- EH controls, SAL 3rd function
- EH controls, joystick lift and tilt
 - Additional integrated roller switches for 3rd function
- Mirrors, heated rearview external with integrated spot mirrors
- Precleaner, HVAC
- Radio, AM/FM/USB/MP3 Bluetooth™
- Radio, AM/FM/CD/USB/MP3 Bluetooth
- Radio, CB ready
- Seat, heated air suspension
- Seat belt, 76 mm retractable, with indicator
- Roof, metallic
- Steering, secondary
- Sun visor, rear
- Windows, rubber mounted
- Windows, with front guard
- Windows, with full guards front, rear and sides
- Full time rear vision display Work Area Vision System (WAVS)

ELECTRICAL AND LIGHTING

- Four additional auxiliary halogen cab mounted work lights or
- Two additional auxiliary front HI LED and two additional auxiliary rear LED cab mounted work lights with two LED work lights in the radiator grill
- Roading lights, halogen with turn signals
- Warning amber strobe beacon
- Two LED stop, turn, tail lights

STARTERS, BATTERIES, AND ALTERNATORS

- Cold start – 240V

CAT CONNECT TECHNOLOGIES

- Link technologies: VIMS™
- Payload technologies:
 - Aggregate Autodig
 - Cat Production Measurement
 - Printer, Cat Production Measurement
- Detect technologies: dedicated display for rear vision camera, full-time activation
- Machine Security System

POWER TRAIN

- Axles
 - Limited slip differentials, front and/or rear
 - Axle oil cooler
 - Ecology drains
 - Extreme temperature seals
 - Seal guards
- Fan, VPF (variable pitch fan), automatic and manual control
- Radiator, high debris with wider fin spacing

LINKAGE

- High lift
- Forestry
- Quick coupler ready

WORK TOOLS

- Performance Series buckets
- Forks, pallet
- Forks, logging

HYDRAULICS

- 3rd function with Ride Control
 - Standard linkage
 - High lift linkage
 - Forestry linkage
- Ride control, 2V

FLUIDS

- Premixed extended life coolant with freeze protection to –50° C

OTHER OPTIONAL EQUIPMENT

- Toolbox
- Fenders, front with mud-flap/rear with extension
- Fenders, roading
- Guard, power train
- Precleaner, turbine
- Precleaner, trash
- Platform, window washing
- Cold weather package
 - Transmission filter bypass
 - Fan pump bypass
 - Jacket water or engine block heater
 - Ether aid ready

OTHER OPTIONAL CONFIGURATIONS

- Aggregate Handler
- Industrial and Waste Handler
- Steel Mill
- Block Handler
- Forestry
- Port and Harbor

For more complete information on Cat products, dealer services, and industry solutions, visit us on the web at www.cat.com

AEHQ7895 (08-2016)

© 2016 Caterpillar
All rights reserved

Materials and specifications are subject to change without notice. Featured machines in photos may include additional equipment. See your Cat dealer for available options.

CAT, CATERPILLAR, SAFETY.CAT.COM, their respective logos, "Caterpillar Yellow" and the "Power Edge" trade dress, as well as corporate and product identity used herein, are trademarks of Caterpillar and may not be used without permission.

VisionLink is a trademark of Trimble Navigation Limited, registered in the United States and in other countries.

